

METRUM

QUALITY SYSTEM FOR THE INSPECTION OF TOP AND SHOULDER OF AEROSOL CANS AND ALUMINIUM DRINKS BOTTLES

Metrum system performs automatic 100% inspection of the curl area, as well as for the wall damage or malformation and neck decoration defects.

BENEFITS

Zero Defects, increasing of productivity & waste reduction. Our experience has provided us with the knowledge and products to ensure reliable detection of defects with a full combinations of coatings, curl shapes, compound colors and designs.

DeCoSystems provided a standard user-friendly solution based upon customer's requirements. The system provided a menu driven operator interface for product selection, and simple changeovers between standard product runs.

INTEGRATION

Metrum can be installed in different position of your production line. It is possible to inspect the aerosol cans directly on the necking machine, in the conveyor belt or in the final inspection machine like a leak detector control machine. Metrum is perfectly integrated in different leak detector machines.

Quality control FOR AEROSOL CANS AND ALUMINIUM BOTTLES



CAMERAS CONFIGURATION

The system is equipped with four digital cameras. The first camera inspect the top of the aerosol including the shoulder. The other three cameras are positioned at 120° for covering the vision of the curl beneath the edge. This innovative configuration guarantee the 360 degrees inspection and it optimize the accuracy of the defect detection.



DeCoSystem
PRINTINSPECTIONMACHINES

METRUM

TECHNICAL FEATURES

Metrum has a very intuitive operator interface with a fast setup.

Standard features are:

- Easy to learn and easy to use GUI interface
- Fast set up (new job can be started in a minute)
- LED lighting system for a diffuse and uniform illumination
- Easily define different areas of job with different tolerance levels
- Simple software but extremely powerful and versatile
- Great reliability in the detection
- Touch screen interface
- Full report and automatic storing of all production process data
- Different Login levels
- Quick zoom function
- Operating in Windows 7

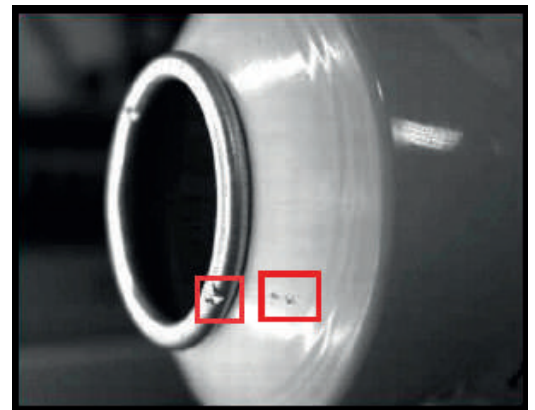
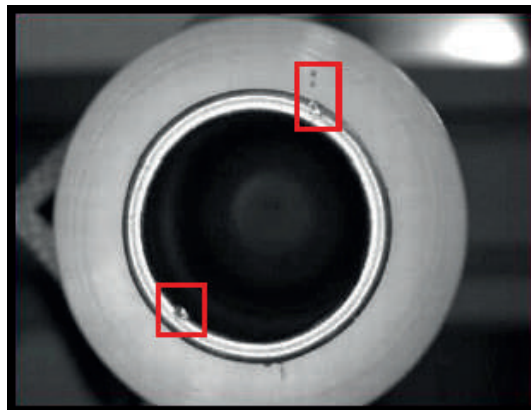
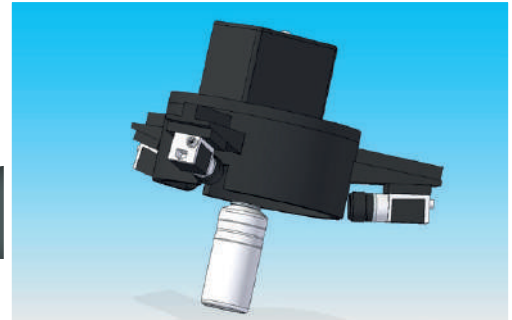
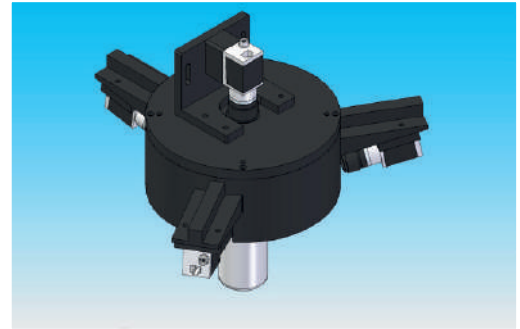

TECHNICAL DATA

	METRUM-M	METRUM-3M	METRUM-M fast	METRUM-3M fast
Inspection	curl diameter aerosol neck	curl diameter underside of the curl aerosol neck	curl diameter aerosol neck	curl diameter underside of the curl aerosol neck
Product	Aerosol cans	Aerosol cans	Aerosol cans	Aerosol cans
Camera	1280x1024 pixel	four 1280x1024 pixel	1280x1024 pixel	four 1280x1024 pixel
Field of view	60mm	60 mm	60mm	60mm
Speed	150 p/min	150 p/min	250 p/min	250 p/min
Resolution	0,05x0,05mm	0,05x0,05mm	0,05x0,05mm	0,05x0,05mm
Min. defect	0,2mm ²	0,2mm ²	0,2mm ²	0,2mm ²

Technical data and system specifications refer to the state at the time of printing. We reserve the right to modify them in the interest of a continuous program of further development.