



METRUM

Inspection machine for dimensional feature measurement on glass bottles.

Metrum is an independent inspection machine directly integrated in the production line and performs a 100% analysis of the production, performing dedicated dimensional checks on each single bottle.

Thanks to a sophisticated set of high-precision cameras, it reliably measures the through-hole of the bottle and the overall height of the bottle as well.

Bottle neck measurement and inspection

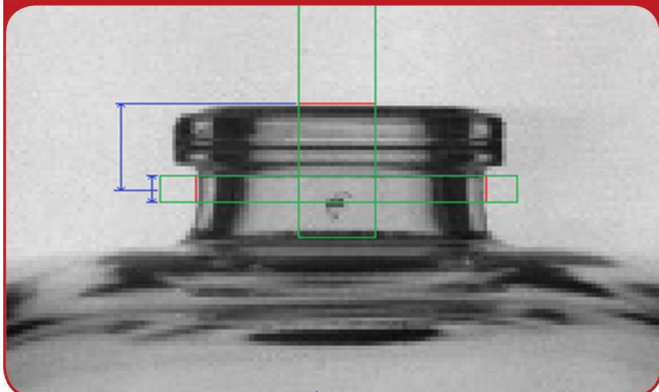

Feature measurement and “Rice Corn”-detection on glass bottles



Drive-through of the bottles with touchless inspection.

The bottles are acquired by high-speed cameras while driving through the module, standing on the conveyor belt.

The inspection is carried out without any need to touch the bottles.

The results of the inspection and measurement procedures can be easily and comfortably evaluated on the two touchscreens mounted on the main frame of the machine.

High-speed high precision cameras for a reliable inspection and feature measurement

The inspection machine is equipped with eight high-speed and high-precision cameras able to acquire the moving bottle, flacon or jar on the conveyor belt.

An adapted and optimized light source configuration warrants a reliable image acquisition.

All operations can be performed by the user by the two touch screens during the running production.

The easy to use and smart software HMI permits a fast and guided set up of the machine and of the inspection jobs.

"Rice-Corn" detection and inspection

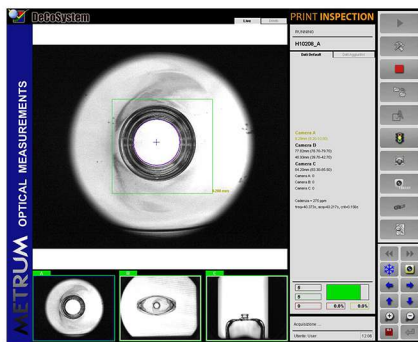
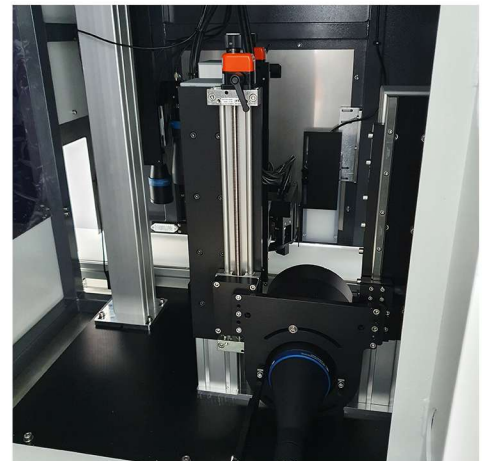

All inspection and measurement results at one glimpse

A dedicated camera box with 6 high-resolution cameras performs the image acquisition of the bottle thread looking at the rice-corn. If it is missing or the measured dimension is out of tolerance, the bottle or flacon is automatically rejected from the production line thanks to the automatic integrated rejection device.

TECHNICAL DATA

| Inspection | Inspection of the through-hole | Bottle height measurement | Neck proportion inspection | Rice-Corn detection and inspection |
|---------------|--------------------------------|---------------------------|----------------------------|------------------------------------|
| Product | Glass flacons/bottles | Glass flacons | Glass flacons/bottles | Glass flacons |
| Camera | 2560x2048 Px BW | 2560x2048 Px BW | 2560x2048 Px BW | 6 x 2560x2048 Px BW |
| Field of view | 40x30mm | 130x100mm | 40x30mm | 30x10mm |
| Speed | 150p/min | 150p/min | 150p/min | 150p/min |
| Resolution | 0,02x0,02mm/px | 0,05x0m05mm/px | 0,02x0,02mm/px | 0,03x0m03mm/px |
| Repeatability | +/- 0,01mm | +/- 0,02mm | +/- 0,01mm | +/- 0,03mm |

Technical data and system specifications refer to the state at the time of printing. We reserve the right to modify them in the interest of a continuous program of further development.